

FAN7384

Half-Bridge Gate-Drive IC

Features

- Floating Channel for Bootstrap Operation to +600V
- Typically 250mA/500mA Sourcing/Sinking Current Driving Capability for Both Channels
- Extended Allowable Negative V_S Swing to -9.8V for Signal Propagation at $V_{DD}=V_{BS}=15V$
- Matched Propagation Delay Below 50ns
- Output In-Phase with Input Signal
- 3.3V and 5V Input Logic Compatible
- Built-in Shoot-Through Prevention Logic
- Built-in Common Mode dv/dt Noise Canceling Circuit
- Built-in UVLO Functions for Both Channels
- Built-in Cycle-by-Cycle Shutdown Function
- Built-in Soft-Off Function
- Built-in Bi-Directional Fault Function
- Built-in Short-Circuit Protection Function

Applications

- Motor Inverter Driver
- Normal Half-Bridge and Full-Bridge Driver
- Switching Mode Power Supply

Description

The FAN7384 is a monolithic half-bridge gate-drive IC designed for high voltage, high speed driving MOSFETs and IGBTs operating up to +600V.

Fairchild's high-voltage process and common-mode noise canceling technique provide stable operation of high-side drivers under high-dv/dt noise circumstances.

An advanced level-shift circuit allows high-side gate driver operation up to $V_S = -9.8V$ (typical) for $V_{BS} = 15V$.

The UVLO circuits prevent malfunction when V_{DD} and V_{BS} are lower than the specified threshold voltage.

Output drivers typically source/sink 250mA/500mA, respectively, which is suitable for half-bridge and full-bridge applications in motor drive systems.

14-SOP

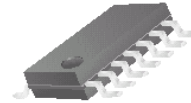

Ordering Information

Part Number	Package	Pb-Free	Operating Temperature Range	Packing Method
FAN7384M ⁽¹⁾	14-SOP	Yes	-40°C ~ 125°C	Tube
FAN7384MX ⁽¹⁾				Tape & Reel

Note:

1. These devices passed wave soldering test by JESD22A-111.

Typical Application Diagrams

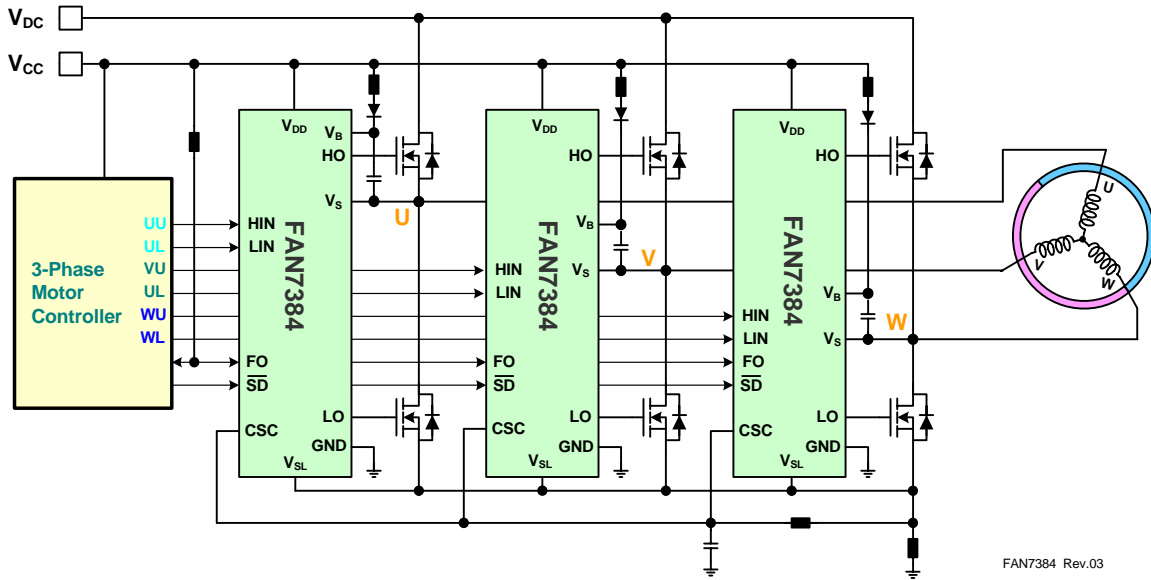

FAN7384 Rev.03

Figure 1. 3-Phase Motor Drive Application

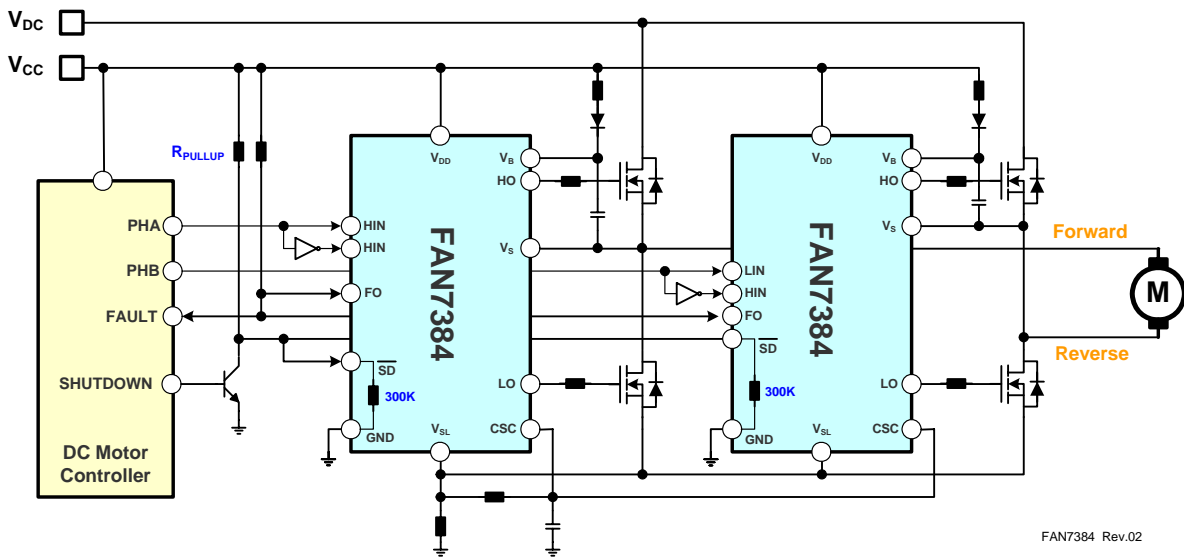

FAN7384 Rev.02

Figure 2. DC Motor Drive Application

Internal Block Diagram

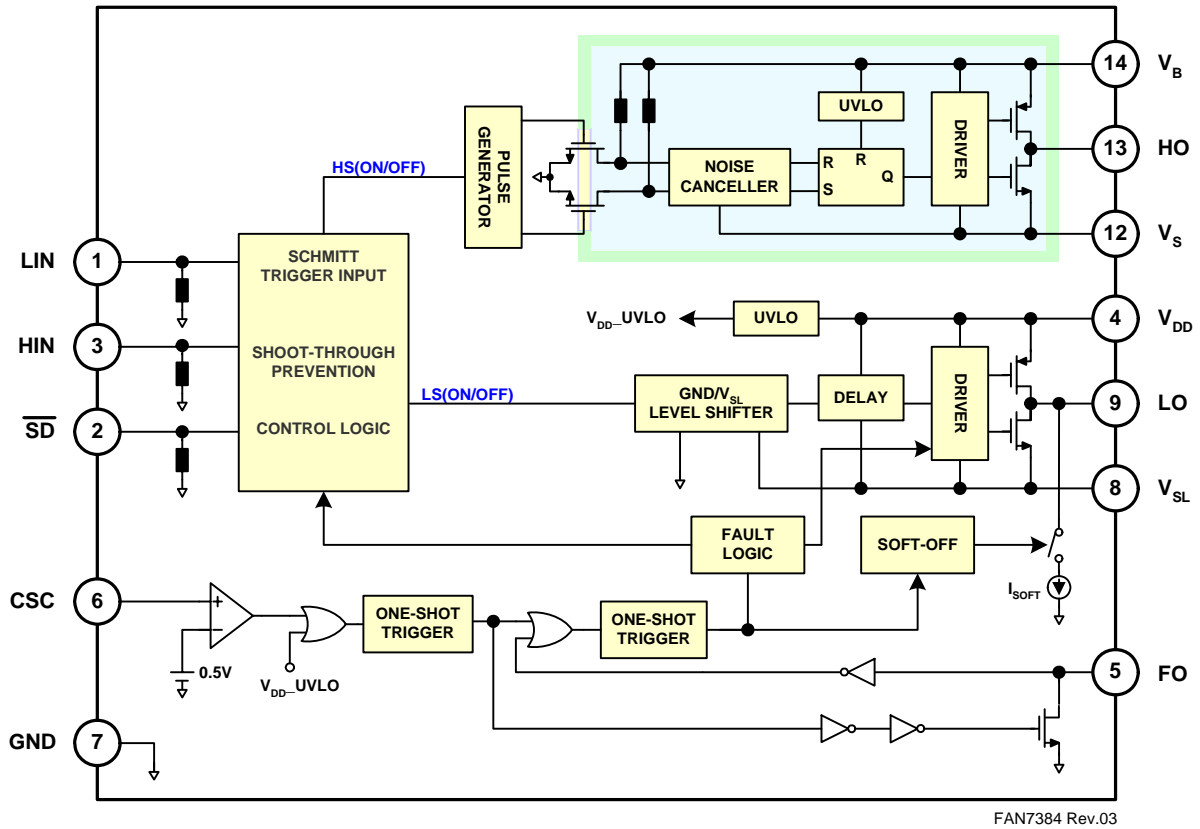

Figure 3. Functional Block Diagram

Pin Configuration

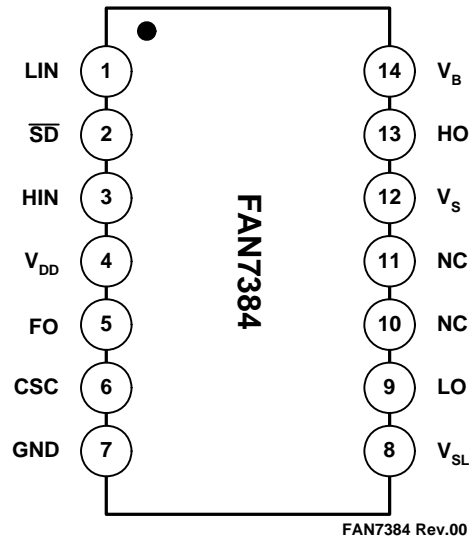

Figure 4. Pin Configuration (Top View)

Pin Definitions

Pin #	Name	Description
1	LIN	Logic Input for low-side gate driver
2	\overline{SD}	Shutdown control input with active low
3	HIN	Logic Input for high-side gate driver
4	V_{DD}	Low-side power supply voltage
5	FO	Bi-direction fault pin with open drain
6	CSC	Short-circuit current detection input
7	GND	Ground
8	V_{SL}	Low-side supply offset voltage
9	LO	Low-side gate driver output
10	NC	Not connection
11	NC	Not connection
12	V_S	High-side floating supply offset voltage
13	HO	High-side gate driver output
14	V_B	High-side floating supply voltage

Absolute Maximum Ratings

Stresses exceeding the absolute maximum ratings may damage the device. The device may not function or be operable above the recommended operating conditions and stressing the parts to these levels is not recommended. In addition, extended exposure to stresses above the recommended operating conditions may affect device reliability. The absolute maximum ratings are stress ratings only. $T_A=25^{\circ}\text{C}$, unless otherwise specified.

Symbol	Parameter	Min.	Max.	Unit
V_S	High-side offset voltage V_S	V_B-25	$V_B+0.3$	V
V_B	High-side floating supply voltage V_B	-0.3	625	V
V_{HO}	High-side floating output voltage	$V_S-0.3$	$V_B+0.3$	V
V_{DD}	Low-side and logic-fixed supply voltage	-0.3	25	V
V_{IN}	Logic input voltage (HIN, LIN, \overline{SD})	-0.3	$V_{DD}+0.3$	V
V_{CSC}	Current sense input voltage	-0.3	$V_{DD}+0.3$	V
V_{FO}	Fault output voltage	-0.3	$V_{DD}+0.3$	V
dV_S/dt	Allowable offset voltage slew rate		50	V/ns
$P_D^{(2)(3)(4)}$	Power dissipation		1.0	W
θ_{JA}	Thermal resistance, junction-to-ambient		110	$^{\circ}\text{C}/\text{W}$
T_J	Junction temperature		150	$^{\circ}\text{C}$
T_S	Storage temperature	-55	150	$^{\circ}\text{C}$

Notes:

- Mounted on 76.2 x 114.3 x 1.6mm PCB (FR-4 glass epoxy material).
- Refer to the following standards:
 - JESD51-2: Integral circuits thermal test method environmental conditions - natural convection
 - JESD51-3: Low effective thermal conductivity test board for leaded surface mount packages
- Do not exceed P_D under any circumstances.

Recommended Operating Conditions

The Recommended Operating Conditions table defines the conditions for actual device operation. Recommended operating conditions are specified to ensure optimal performance to the datasheet specifications. Fairchild does not recommend exceeding them or designing to Absolute Maximum Ratings.

Symbol	Parameter	Condition	Min.	Max.	Unit
V_B	High-side floating supply voltage		V_S+13	V_S+20	V
V_S	High-side floating supply offset voltage		$6-V_{DD}$	600	V
V_{DD}	Supply voltage		13	20	V
V_{HO}	High-side output voltage		V_S	V_B	V
V_{LO}	Low-side output voltage		GND	V_{DD}	V
V_{IN}	Logic input voltage (HIN, LIN, \overline{SD})		GND	V_{DD}	V
V_{FO}	Fault output voltage		-0.3	$V_{DD}+0.3$	V
T_A	Ambient temperature		-40	125	$^{\circ}\text{C}$

Electrical Characteristics

V_{BIAS} (V_{DD} , V_{BS}) = 15.0V, T_A = 25°C, unless otherwise specified. The V_{IN} and I_{IN} parameters are referenced to GND. The V_O and I_O parameters are referenced to V_S and GND and are applicable to the respective outputs HO and LO.

Symbol	Characteristics	Condition	Min.	Typ.	Max.	Unit
LOW SIDE POWER SUPPLY SECTION						
I_{QDD}	Quiescent V_{DD} supply current	$V_{LIN}=0V$ or 5V		600	800	μA
I_{PDD}	Operating V_{DD} supply current	$f_{LIN}=20kHz$, rms value		950	1300	μA
V_{DDUV+}	V_{DD} supply under-voltage positive going threshold	$V_{DD}=\text{Sweep}$	10.9	11.9	12.9	V
V_{DDUV-}	V_{DD} supply under-voltage negative going threshold	$V_{DD}=\text{Sweep}$	10.4	11.4	12.4	V
V_{DDHYS}	V_{DD} supply under-voltage lockout hysteresis	$V_{DD}=\text{Sweep}$		0.5		V
BOOTSTRAPPED POWER SUPPLY SECTION						
V_{BSUV+}	V_{BS} supply under-voltage positive going threshold	$V_{BS}=\text{Sweep}$	10.6	11.5	12.4	V
V_{BSUV-}	V_{BS} supply under-voltage negative going threshold	$V_{BS}=\text{Sweep}$	10.1	11.0	11.9	V
V_{BSHYS}	V_{BS} supply under-voltage lockout hysteresis	$V_{BS}=\text{Sweep}$		0.5		V
I_{LK}	Offset supply leakage current	$V_B=V_S=600V$			10	μA
I_{QBS}	Quiescent V_{BS} supply current	$V_{HIN}=0V$ or 5V		50	90	μA
I_{PBS}	Operating V_{BS} supply current	$f_{HIN}=20kHz$, rms value		400	600	μA
GATE DRIVER OUTPUT SECTION						
V_{OH}	High-level output voltage, $V_{BIAS}-V_O$	$I_O=0mA$ (No Load)			100	mV
V_{OL}	Low-level output voltage, V_O	$I_O=0mA$ (No Load)			100	mV
I_{O+}	Output HIGH short-circuit pulse current	$V_O=0V$, $V_{IN}=5V$ with $PW<10\mu s$	200	250		mA
I_{O-}	Output LOW short-circuit pulsed current	$V_O=15V$, $V_{IN}=0V$ with $PW<10\mu s$	420	500		mA
V_S	Allowable negative V_S pin voltage for IN signal propagation to H_O			-9.8	-7.0	V
V_{SL-GND}	$V_{SL-GND}/GND-V_{SL}$ voltage educability		-7.0		7.0	V
SHUTDOWN CONTROL SECTION (SD)						
$\overline{SD+}$	Shutdown "1" input voltage				1.2	V
$\overline{SD-}$	Shutdown "0" input voltage		2.5			V
LOGIC INPUT SECTION (HIN, LIN)						
V_{IH}	Logic "1" input voltage		2.5			V
V_{IL}	Logic "0" input voltage				1.2	V
V_{INHYS}	Logic input hysteresis voltage			0.5		V
I_{IN+}	Logic "1" input bias current	$V_{IN}=5V$	10	15	20	μA
I_{IN-}	Logic "0" input bias current	$V_{IN}=0V$			2.0	μA

Electrical Characteristics (Continued)

V_{BIAS} (V_{DD} , V_{BS}) = 15.0V, T_A = 25°C, unless otherwise specified. The V_{IN} and I_{IN} parameters are referenced to GND. The V_O and I_O parameters are referenced to GND and V_S is applicable to HO and LO.

Symbol	Characteristics	Condition	Min.	Typ.	Max.	Unit
SHORT-CIRCUIT PROTECTION						
V_{CSCREF}	Short-circuit detector reference voltage		0.47	0.50	0.53	V
I_{CSCIN}	Short-circuit input current	$V_{CSCIN}=1V$, $R_{CSCIN}=100K\Omega$	5	10	15	μA
I_{SOFT}	Soft turn-off source current	$V_{DD}=15V$	5	10	15	mA
$-V_{CSC}$	Negative CSC pin immunity ⁽⁵⁾	Voltage on CSC pin up to -12V, Time<2 μs			-20	V
FAULT DETECTION SECTION						
V_{FINH}	Fault input high level voltage		2.5			V
V_{FINL}	Fault input low level voltage				1.2	V
V_{FINHYS}	Fault input hysteresis voltage ⁽⁵⁾			0.5		V
V_{FOH}	Fault output high level voltage	$V_{CSC}=0V$, $R_{PULL-UP}=4.7K\Omega$	4.7			V
V_{FOL}	Fault output low level voltage	$V_{CSC}=1V$, $I_{FO}=2mA$			0.8	V
t_{FO}	Fault output pulse width	$V_{CSCIN}=1V$		60	100	μs

Note:

5. These parameters guaranteed by design.

Dynamic Electrical Characteristics

$T_A=25^\circ C$, V_{BIAS} (V_{DD} , V_{BS}) = 15.0V, $V_S = GND$, $C_{Load} = 1000pF$ unless otherwise specified.

Symbol	Parameter	Conditions	Min.	Typ.	Max.	Unit
t_{on}	Turn-on propagation delay	$V_S=0V$		180	260	ns
t_{off}	Turn-off propagation delay	$V_S=0V$ or 600V ⁽⁵⁾		170	240	ns
t_r	Turn-on rise time			50	100	ns
t_f	Turn-off fall time			30	80	ns
MT	Delay matching				50	ns
DT	Dead-time		80	120	170	ns
t_{UVFLT}	Under-voltage filtering time ⁽⁵⁾			16		μs
t_{CSCFLT}	CSC pin filtering time ⁽⁵⁾			300		ns
t_{CSCFO}	Time from CSC triggering to FO ⁽⁵⁾			350		ns
t_{CSCLO}	Time from CSC triggering to low-side gate output ⁽⁵⁾	From $V_{CSC}=1V$ to starting gate turn-off		600		ns
t_{SDFO}	Shutdown to FO propagation delay ⁽⁵⁾			60		ns
t_{SDOFF}	Shutdown to HIGH/LOW-side gate off ⁽⁵⁾			100		ns

Note:

5. These parameters guaranteed by design.

Typical Characteristics

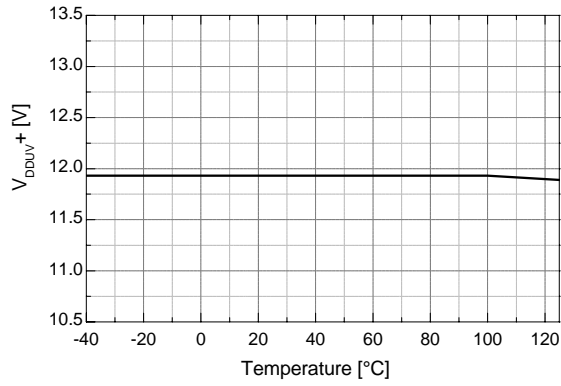

Figure 5. V_{DD} UVLO (+) vs. Temperature

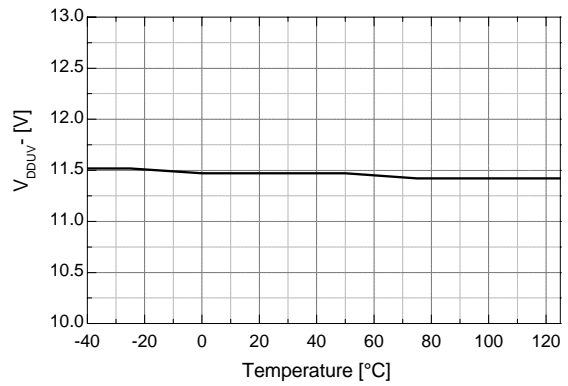

Figure 6. V_{DD} UVLO (-) vs. Temperature

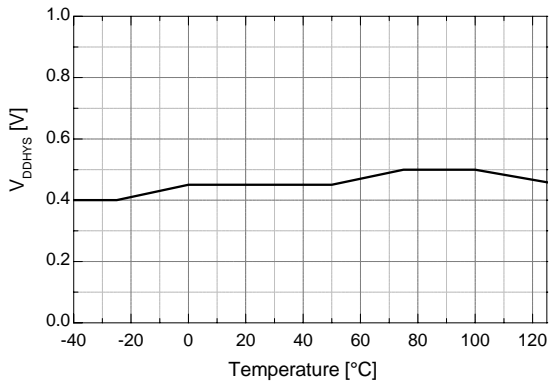

Figure 7. V_{DD} UVLO Hysteresis vs. Temperature

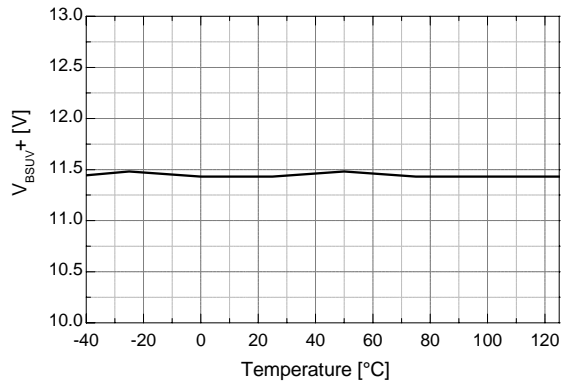

Figure 8. V_{BS} UVLO (+) vs. Temperature

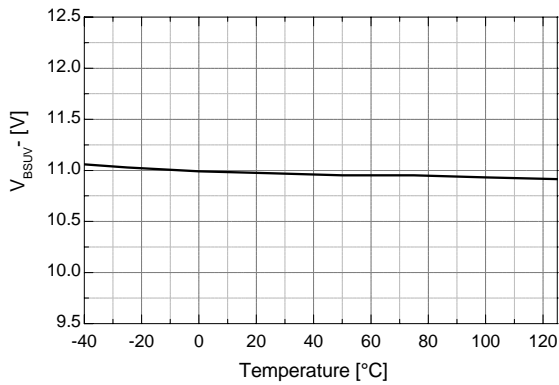

Figure 9. V_{BS} UVLO (-) vs. Temperature

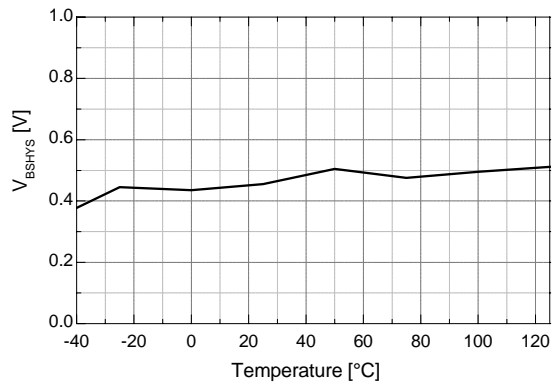

Figure 10. V_{BS} UVLO Hysteresis vs. Temperature

Typical Characteristics (Continued)

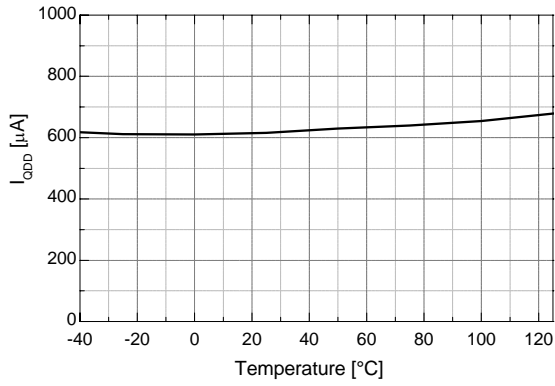

Figure 11. V_{DD} Quiescent Current vs. Temperature

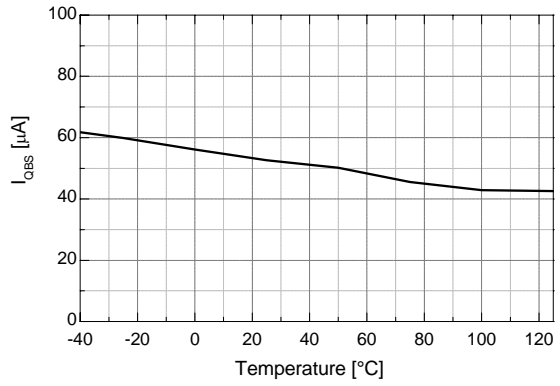

Figure 12. V_{BS} Quiescent Current vs. Temperature

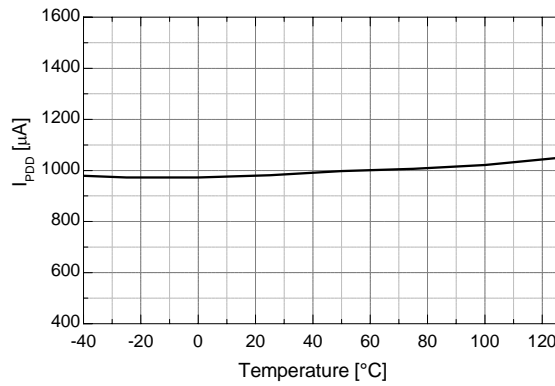

Figure 13. V_{DD} Operating Current vs. Temperature

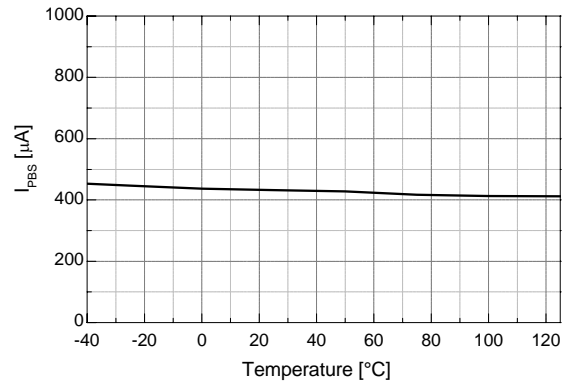

Figure 14. V_{BS} Operating Current vs. Temperature

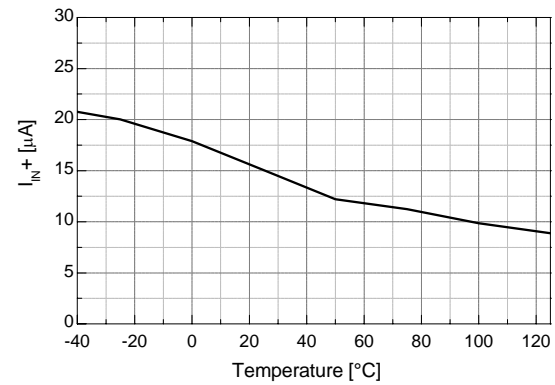

Figure 15. Logic Input Current vs. Temperature

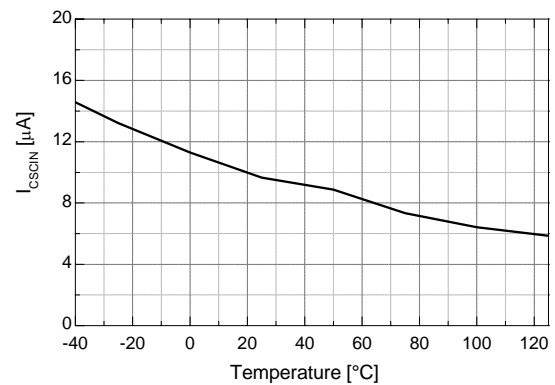

Figure 16. I_{CSCIN} vs. Temperature

Typical Characteristics (Continued)

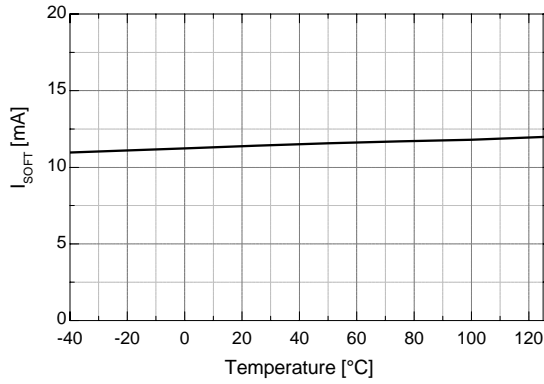

Figure 17. I_{SOFT} vs. Temperature

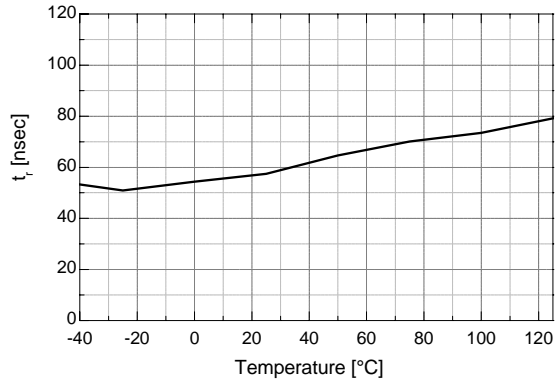

Figure 18. Turn-on Rising Time vs. Temperature

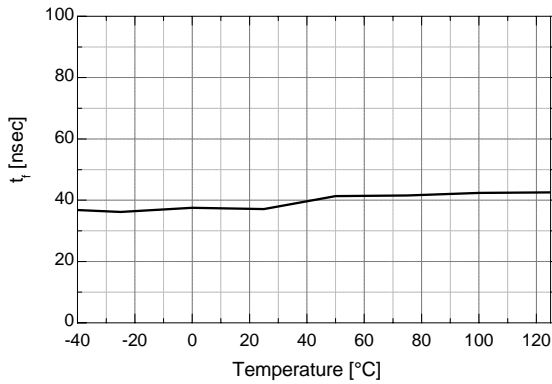

Figure 19. Turn-off Falling Time vs. Temperature

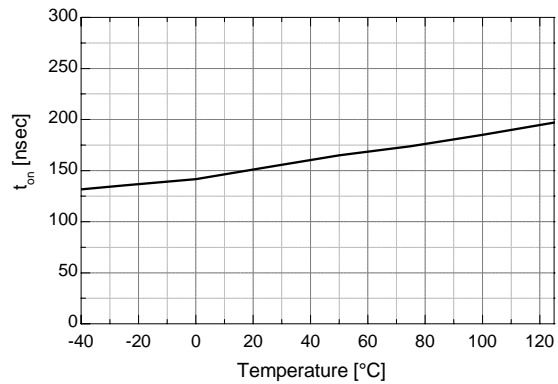

Figure 20. Turn-on Delay Time vs. Temperature

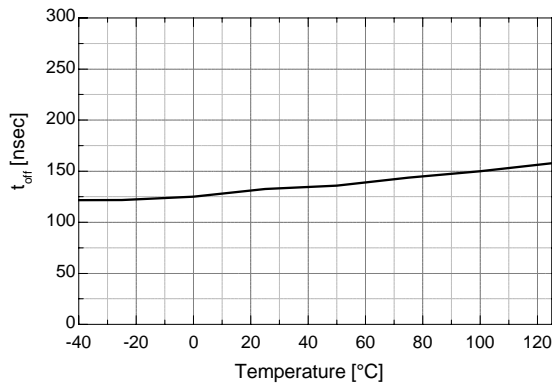

Figure 21. Turn-off Delay Time vs. Temperature

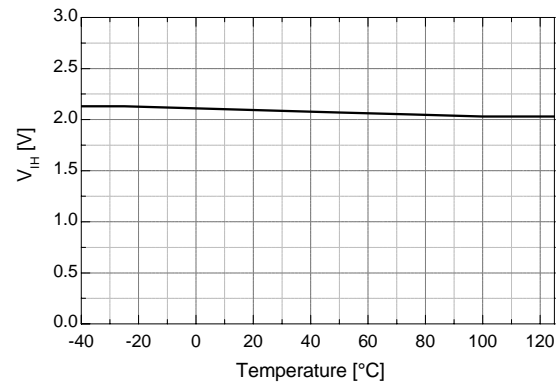

Figure 22. Logic Input High Voltage vs. Temperature

Typical Characteristics (Continued)

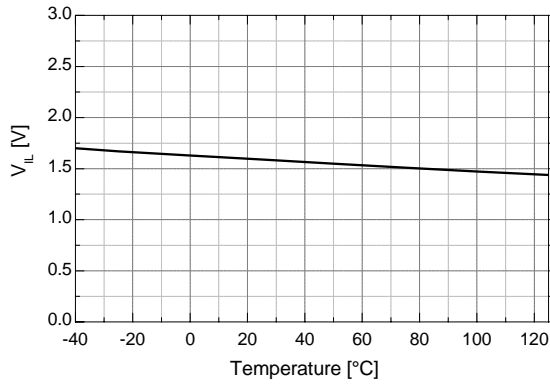

Figure 23. Logic Input Low Voltage vs. Temperature

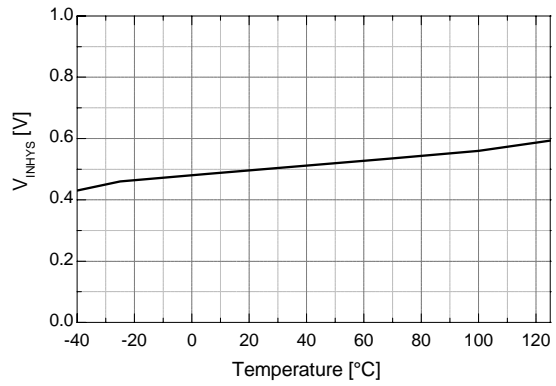

Figure 24. Logic Input Hysteresis vs. Temperature

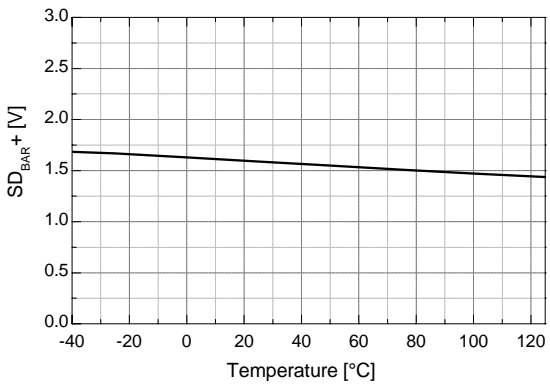

Figure 25. $\overline{\text{SD}}$ Positive Threshold vs. Temperature

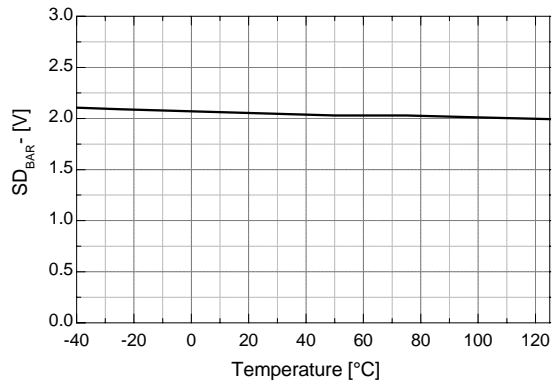

Figure 26. $\overline{\text{SD}}$ Negative Threshold vs. Temperature

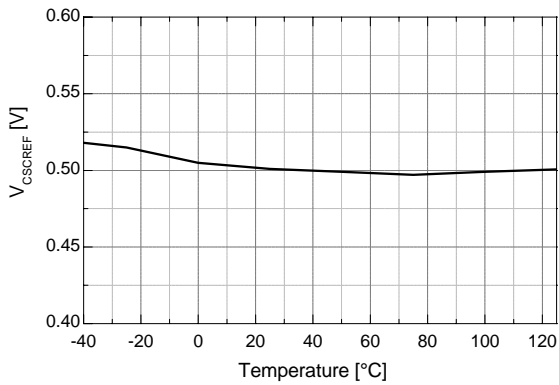

Figure 27. V_{CSCREF} vs. Temperature

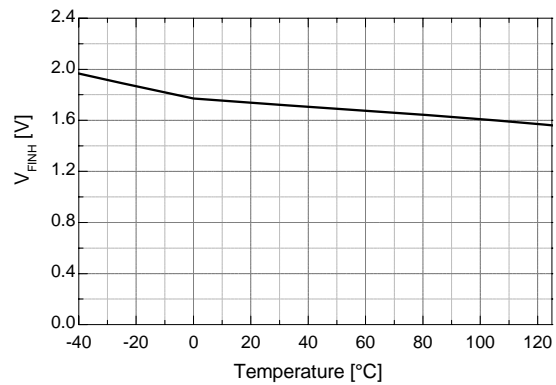

Figure 28. Fault Input High Voltage vs. Temperature

Typical Characteristics (Continued)

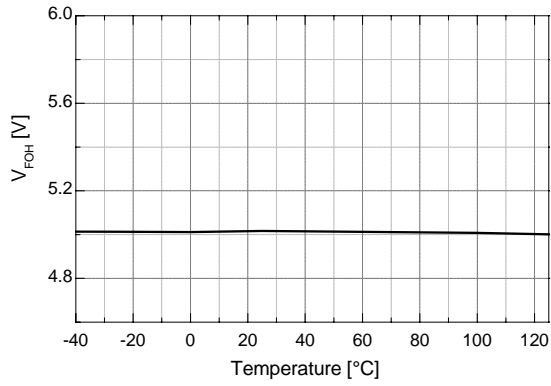

Figure 29. Fault Output High Voltage vs. Temperature

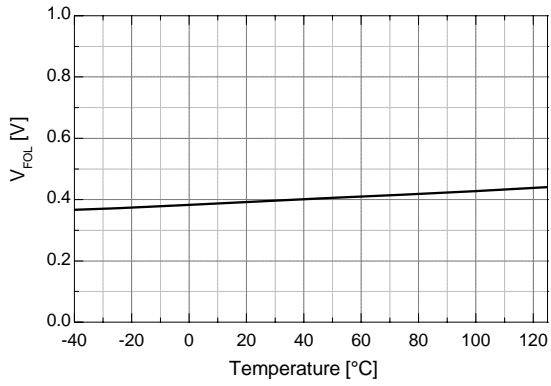

Figure 30. Fault Output Low Voltage vs. Temperature

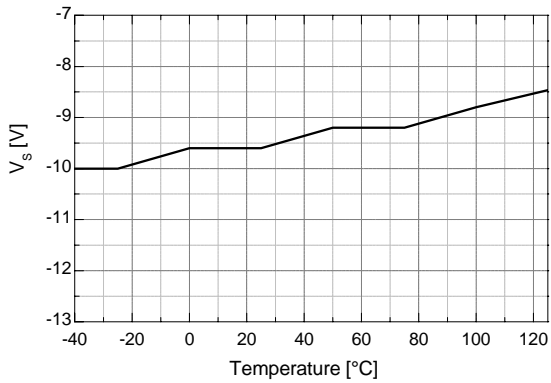

Figure 31. Allowable Negative V_S Voltage for Signal Propagation to High Side vs. Temperature

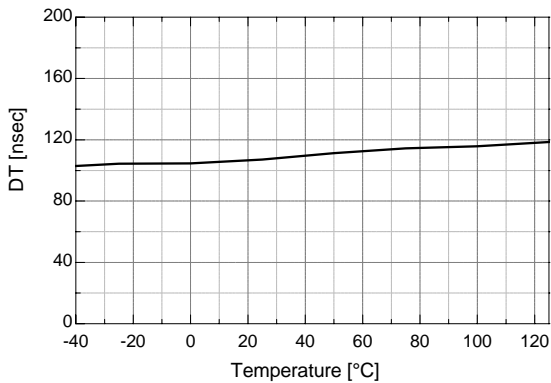

Figure 32. Dead Time vs. Temperature

Switching Time Definitions

The overall switching timing waveforms definition of FAN7384 as shown Figure 33.

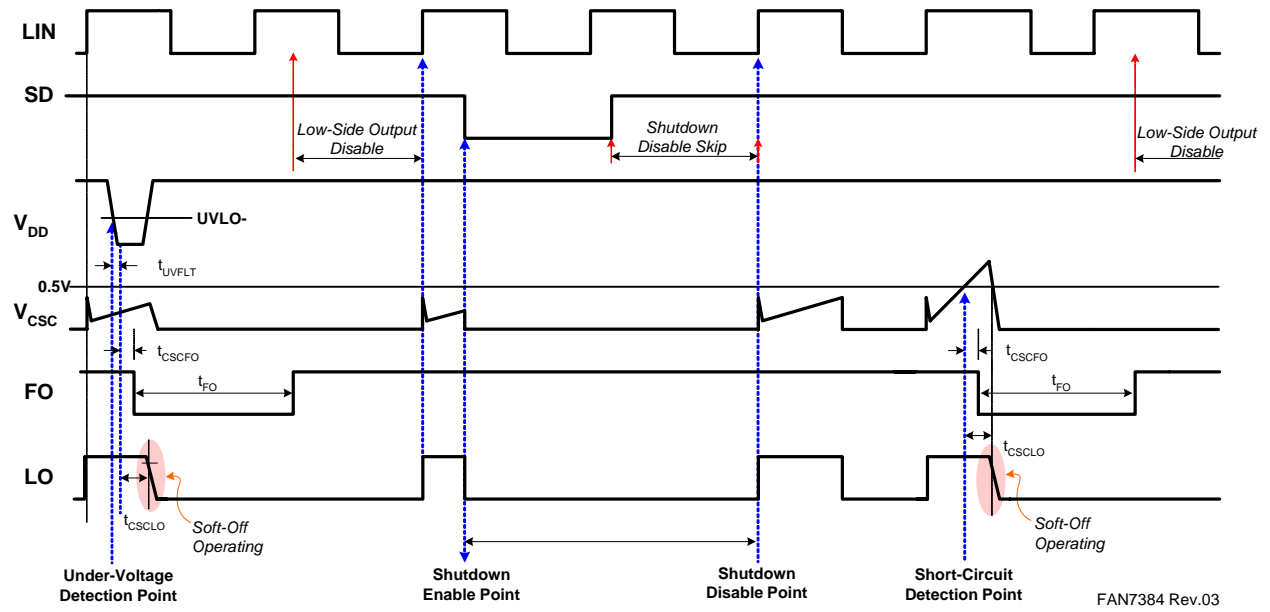

Figure 33. Switching Timing Waveforms Definition

Typical Application Information

1. Protection Function

1.1 Under-Voltage Lockout (UVLO)

The high- and low-side drivers include under-voltage lockout (UVLO) protection circuitry that monitors the supply voltage (V_{DD}) and bootstrap capacitor voltage (V_{BS}) independently. It can be designed to prevent malfunction when V_{DD} and V_{BS} are lower than the specified threshold voltage. Moreover, the UVLO hysteresis prevents chattering during power supply transitions. If the supply voltage (V_{DD}) maintains an under-voltage condition over under-voltage filtering times (typically $16\mu\text{s}$), the fault and soft-off circuits are activated, as shown Figure 34.

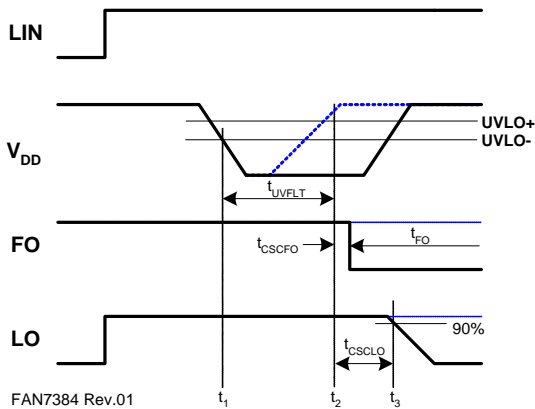

Figure 34. Waveforms for Under-Voltage Lockout

1.2 Shoot-Through Prevention Function

The FAN7384 has a shoot-through prevention circuitry that monitors the high- and low-side inputs. It can be designed to prevent outputs of high- and low-side turning on at same time, as shown Figure 35 and 36.

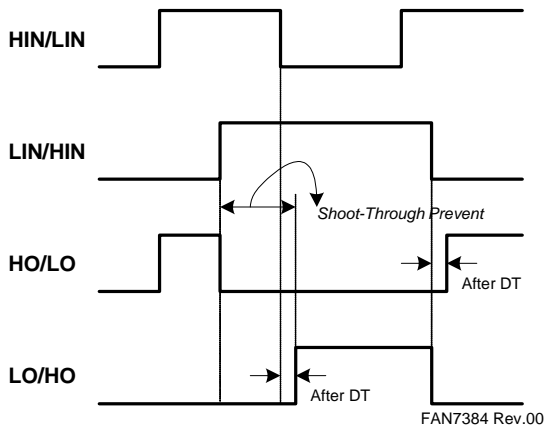

Figure 35. Waveforms for Shoot-Through Prevention

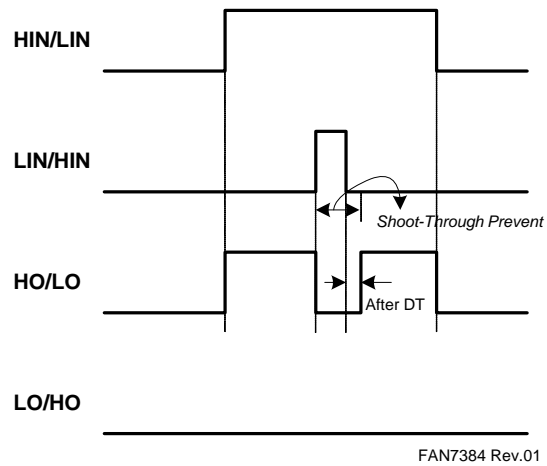

Figure 36. Waveforms for Shoot-Through Prevention

1.3 Over-Current Protection Function

The FAN7384 has over-current detection circuitry that monitors the current-by-current sensing resistor connected from the low-side switch source (V_{SL}) to ground.

It is a built-in time-filler from the over-current event to prevent malfunction from a noise source, such as leading-edge pulse in inductive load application, as shown Figure 37.

The sensing current is calculated as follows:

$$I_{CS} = \frac{V_{CSCREF}}{R_{CS}} [A] \quad (1)$$

where,

V_{CSCREF} : Reference voltage of current sense comparator

R_{CS} : Current sensing resistor

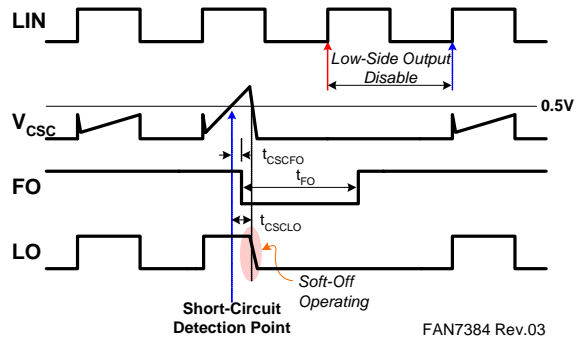

Figure 37. Waveforms for Short-Circuit Protection

2. Layout Considerations

For optimum performance, considerations must be taken during printed circuit board (PCB) layout.

2.1 Supply Capacitors

If the output stages are able to quickly turn on a switching device with a high value of current, the supply capacitors must be placed as close as possible to the device pins (V_{DD} and GND for the ground-tied supply, V_B and V_S for the floating supply) to minimize parasitic inductance and resistance.

2.2 Gate-Drive Loop

Current loops behave like antennae, able to receive and transmit noise. To reduce the noise coupling/emission and improve the power switch turn-on and off performance, gate-drive loops must be reduced as much as possible.

2.3 Ground Plane

To minimize noise coupling, the ground plane should not be placed under or near the high-voltage floating side.

Package Dimensions

14-SOP

Dimensions are in millimeters unless otherwise noted.

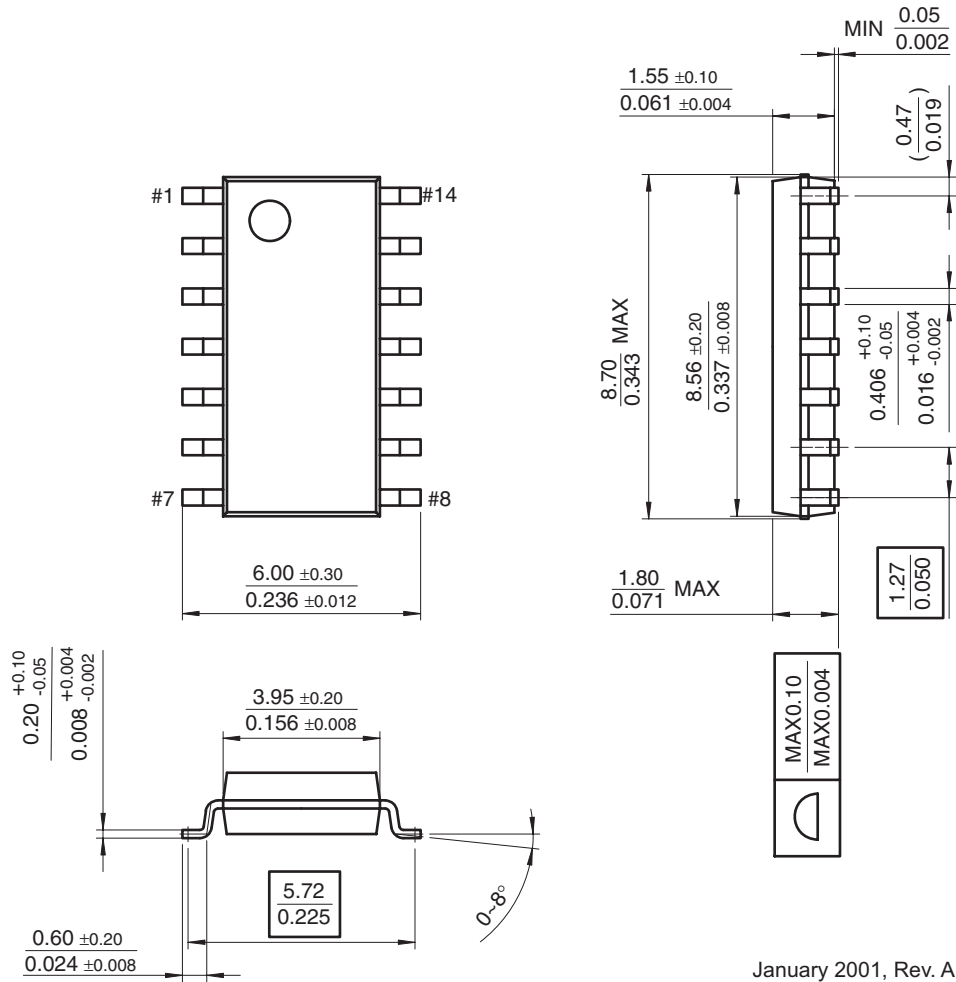

January 2001, Rev. A

Figure 38. 14-Lead Small Outline Package (SOP)



TRADEMARKS

The following are registered and unregistered trademarks Fairchild Semiconductor owns or is authorized to use and is not intended to be an exhaustive list of all such trademarks.

ACE ^x	HiSeC TM	PowerTrench [®]	TinyLogic [®]
Across the board. Around the world. TM	<i>i-Lo</i> TM	Programmable Active Droop TM	TINYOPTO TM
ActiveArray TM	ImpliedDisconnect TM	QFET [®]	TinyPower TM
Bottomless TM	IntelliMAX TM	QS TM	TinyWire TM
Build it Now TM	ISOPLANAR TM	QT Optoelectronics TM	TruTranslation TM
CoolFET TM	MICROCOUPLER TM	Quiet Series TM	μSerDes TM
CROSSVOLT TM	MicroPak TM	RapidConfigure TM	UHC [®]
CTL TM	MICROWIRE TM	RapidConnect TM	UniFET TM
Current Transfer Logic TM	MSX TM	ScalarPump TM	VCX TM
DOME TM	MSXPro TM	SMART START TM	Wire TM
E ² C ^{MOS} TM	OCX TM	SPM [®]	
EcoSPARK [®]	OCXPro TM	SuperFET TM	
EnSigna TM	OPTOLOGIC [®]	SuperSOT TM -3	
FACT Quiet Series TM	OPTOPLANAR [®]	SuperSOT TM -6	
FACT [®]	PACMAN TM	SuperSOT TM -8	
FAST [®]	POP TM	TCM TM	
FASTr TM	Power220 [®]	The Power Franchise [®]	
FPS TM	Power247 [®]	 TM	
FRFET [®]	PowerEdge TM	TinyBoost TM	
GlobalOptoisolator TM	PowerSaver TM	TinyBuck TM	
GTO TM			

DISCLAIMER

FAIRCHILD SEMICONDUCTOR RESERVES THE RIGHT TO MAKE CHANGES WITHOUT FURTHER NOTICE TO ANY PRODUCTS HEREIN TO IMPROVE RELIABILITY, FUNCTION OR DESIGN. FAIRCHILD DOES NOT ASSUME ANY LIABILITY ARISING OUT OF THE APPLICATION OR USE OF ANY PRODUCT OR CIRCUIT DESCRIBED HEREIN; NEITHER DOES IT CONVEY ANY LICENSE UNDER ITS PATENT RIGHTS, NOR THE RIGHTS OF OTHERS. THESE SPECIFICATIONS DO NOT EXPAND THE TERMS OF FAIRCHILD'S WORLDWIDE TERMS AND CONDITIONS, SPECIFICALLY THE WARRANTY THEREIN, WHICH COVERS THESE PRODUCTS.

LIFE SUPPORT POLICY

FAIRCHILD'S PRODUCTS ARE NOT AUTHORIZED FOR USE AS CRITICAL COMPONENTS IN LIFE SUPPORT DEVICES OR SYSTEMS WITHOUT THE EXPRESS WRITTEN APPROVAL OF FAIRCHILD SEMICONDUCTOR CORPORATION.

As used herein:

1. Life support devices or systems are devices or systems which, (a) are intended for surgical implant into the body or (b) support or sustain life, and (c) whose failure to perform when properly used in accordance with instructions for use provided in the labeling, can be reasonably expected to result in a significant injury of the user.
2. A critical component in any component of a life support, device, or system whose failure to perform can be reasonably expected to cause the failure of the life support device or system, or to affect its safety or effectiveness.

PRODUCT STATUS DEFINITIONS

Definition of Terms

Datasheet Identification	Product Status	Definition
Advance Information	Formative or In Design	This datasheet contains the design specifications for product development. Specifications may change in any manner without notice.
Preliminary	First Production	This datasheet contains preliminary data; supplementary data will be published at a later date. Fairchild Semiconductor reserves the right to make changes at any time without notice to improve design.
No Identification Needed	Full Production	This datasheet contains final specifications. Fairchild Semiconductor reserves the right to make changes at any time without notice to improve design.
Obsolete	Not In Production	This datasheet contains specifications on a product that has been discontinued by Fairchild Semiconductor. The datasheet is printed for reference information only.